



angle design  
DN 25

## PLASTIC PRESSURE REDUCER LPR<sup>®T</sup>

### Application

These plastic pressure reducers are used for reducing air and gas pressure in chemical plant construction. The regulator is specially designed for inert-gas blanketing and pressure blanketing agitating tubs, storage tanks and containers with an inert gas such as nitrogen.

### Design

The large proportioned, spring-loaded diaphragm actuator with directly-controlled valve seat ensures precise control with low hysteresis. The regulators function without auxiliary power supply. High overpressure strength and safe regulator function is achieved by means of the supported diaphragm with long spindle guide. The regulator has a low degree of clearance volume and is self-draining.

### Description

The components coming in contact with the product are manufactured from plastic PP/PP<sub>el.</sub>, PVDF. The diaphragm and seals are made of PTFE and the regulator seat is made of perfluoroelastomer (FFKM – Isolast®, Chemraz®, Kalrez®) as standard.

These materials guarantee high corrosion resistance and excellent sealing, even at zero flow.

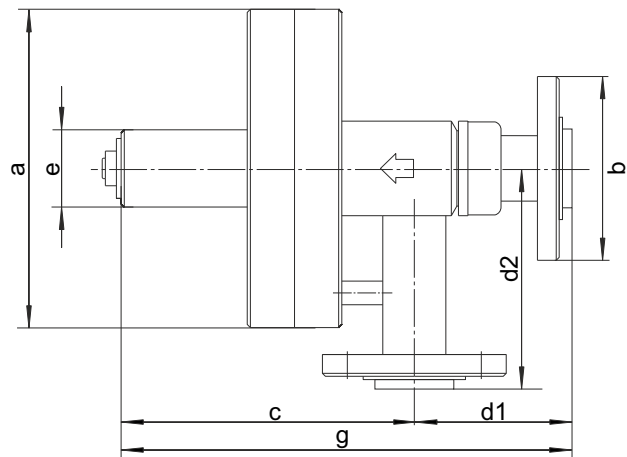
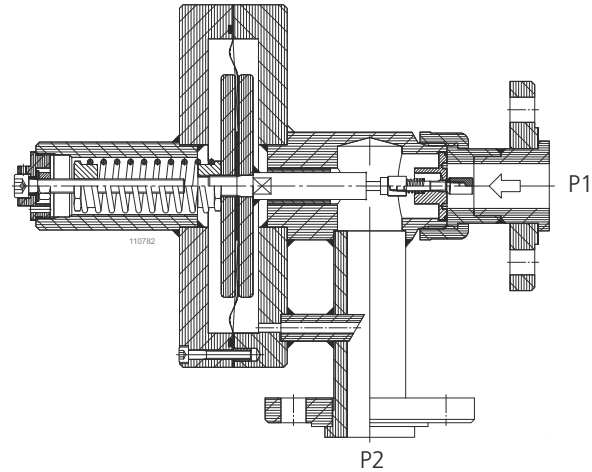
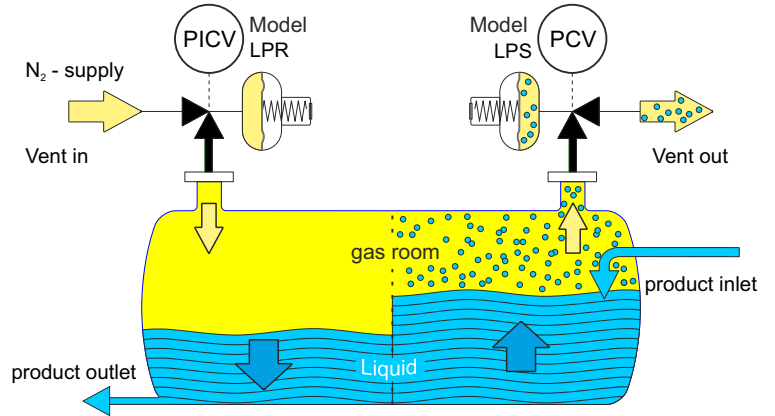

### Technical data

<b>Nominal diameter:</b>	DN 25 / 1"		
<b>Regulating range P2:</b>	L..	to 500 mbar	
<b>Inlet pressure P1:</b>	max. 10 bar		
<b>Vakuum proof</b>			
<b>Pressure connections:</b>	Flange		
<b>Weight:</b>	PP 2,8 kg PVDF 4,5 kg		
<b>*Temperature:</b>	PP, PP <sub>el.</sub>	-20 ° to +80 °C	
	PVDF	-20 ° to +140 °C	
<b>Testing and inspection:</b>	According to IEC 60534-4		
<b>Pressure tightness:</b>	Bubble tight sealing category VI		

\*Dependent on pressure conditions

Model dimensions	pressure connection	a	b	c	g	d1 x d2	e
LPRT-025.-...-...-... in plastic design	DN25 PN10 ANSI 1" 150 lbs	∅ 202	∅115	~200	~300	Standard 100 x 140	∅49



## MODEL CODE LPR<sup>®</sup>T PLASTIC

1			2			3			4			5			6			7		
Design						Flow capacity			Regulating pressure range			Material			Options			Specials		
LP	R	T	-	025	.	-	..	-	...	-	...	-	...	-	.	-	...	Xn		

D	Flange:	DIN EN 1092-1, DN 25 PN 16
A	Flange:	ANSI B 16.5, 1" 150 lbs

### 3 Flow capacity

07	Seat	ø7 mm
12	Seat	ø12 mm
16	Seat	ø16 mm

### 4 Regulating pressure range P2 (mbar)

L01	2 to 10	L10	16 to 100
L02	4 to 20	L20	30 to 200
L05	8 to 50	L50	on request

### 5 Material

	Housing/ internal components/ upper section	Seat seal	Diaphragm/ Regulating range
P	PP/PP/PP	K FFKM	P PTFE L..
Y	PP/PVDF/PP	C FFKM kon-forms to FDA	
D	PVDF/PVDF/PP		
V	PVDF/PVDF/PVDF		
E	PPel./PVDF/PPel.		

The housing/internal components/spring housing, seat and diaphragms can be combined in any order.

### 6 Options

D	Differential pressure connection
E	BSP 1/4" external impulse connection

### 7 Specials

X0 If you require, for example, PED, special connections, rain hood ..., please enter an X in this field with the number of desired Specials. Each of the specials must be described in writing. The analysis of materials 3.1 B and ATEX - certificates cannot be issued for plastic models.  
 X1  
 X2  
 •  
 •  
 Xn For special versions and certifications, please contact the manufacturer or the appropriate sales representative.

### Flow table [flow quantities in Nm<sup>3</sup>/h]

P1 [bar rel.]	0.15	0.25	0.40	0.65	1.0	1.5	2.0	4.0	6.0	10	
10	10	14	18	22	26	34	42	72	100	155	ø7 mm
	22	31	42	54	65	85	100	170	235	360	ø12 mm
	50	70	85	115	145	180	220	375	515	790	ø16 mm
100	7	14	18	22	26	34	42	72	100	155	ø7 mm
	16	31	42	54	65	85	100	170	235	360	ø12 mm
	40	70	85	115	145	180	220	375	515	790	ø16 mm
200	-	6	18	22	26	34	42	72	100	155	ø7 mm
	-	14	42	54	65	85	100	170	235	360	ø12 mm
	-	35	85	115	145	180	220	375	515	790	ø16 mm

The flow capacity is the same in the supercritical operating range (guide value: P2 < 0.5 x P1). It is recommended to design for operation at a maximum of 70% of the flow values.  
 P1 = supply pressure P2 = regulating pressure

### Dependency on inlet pressure (per -1 bar / +1 bar change in P1)

Seat ø7 mm	- 3 mbar / + 3 mbar	Seat ø16 mm	- 13 mbar / + 13 mbar
Seat ø12 mm	- 8 mbar / + 8 mbar		

### Pressure / flow characteristic

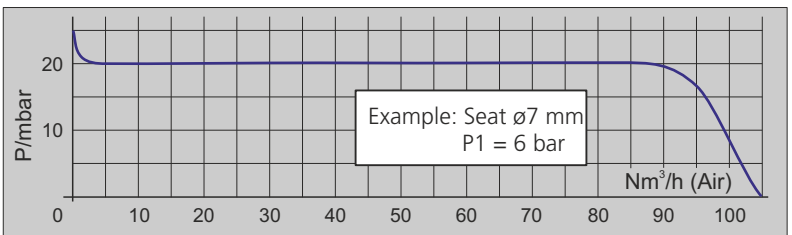

### Installation

The preferred installation position is with vertical diaphragm housing and horizontal input. Pressure fixed unit is adjusted in this position. The output pressure increases by approximately 4 mbar for installation with horizontal diaphragm housing. The installation position must be specified.

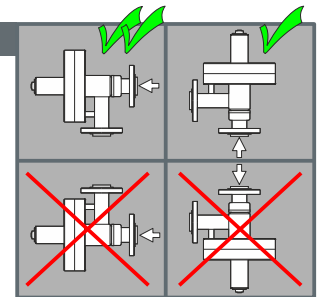

### Mounting and start up

- Before connecting the pressure regulator please make sure
- LPRT adjust reduced pressure: (Relative pressure)
- 1.1 to compare the plant data with the name plate
- 1.2 the values marked on the name plate are the values measured during our functional inspection
- 1.3 to check the corrosion resistance of the material
- 1.4 to blow out impurities in the pipes
- 1.5 to note the flow direction – it is marked with an arrow on the housing
- 1.6 to open inlet pipes slowly.
- 2.1 set a light flow (1Nm<sup>3</sup>/h). Set the pressure +/- as required using a hexagonal wrench
- 2.2 the setting can be secured with a seal.
- 3 Adjust the LPRT differential pressure (-D) with the servo-regulator
- 3.1 if the D-connection is pressurised with the servo-pressure, the working pressure is added by the servo-pressure.